



CB900 HORNET



- **PACKING LIST:**
- **1X LINK PIPE**
- **1X CARBON GASKET**
- **3X CLAMPS**
- **2X SILENCERS AND STRAPS WITH RUBBER INSERTS**
- **2X MOUNTING BRACKETS**
- **2X SPACERS**
- **MOUNTING HARDWARE**
- **1X TUBE OF SILICON SEALANT**

- **Fitting Instructions**

- We advise that this product is fitted by an experienced motorcycle mechanic.
- Please check packing list before you start.
- Secure motorcycle on level ground using a paddock stand. Recommended!
- Refer to workshop manual for disassembly procedure.
- Remove seat and seat cowl.
- Remove rear shock absorber.

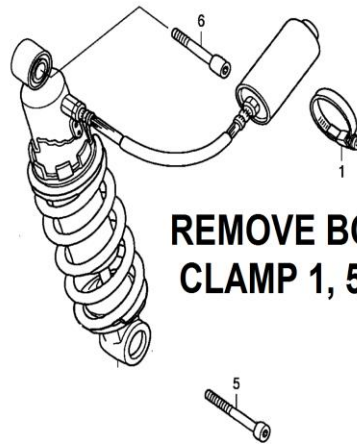

REMOVE BOLTS AND CLAMP 1, 5 AND 6

- Remove standard silencers.

REMOVE SILENCERS AND MID-PIPE

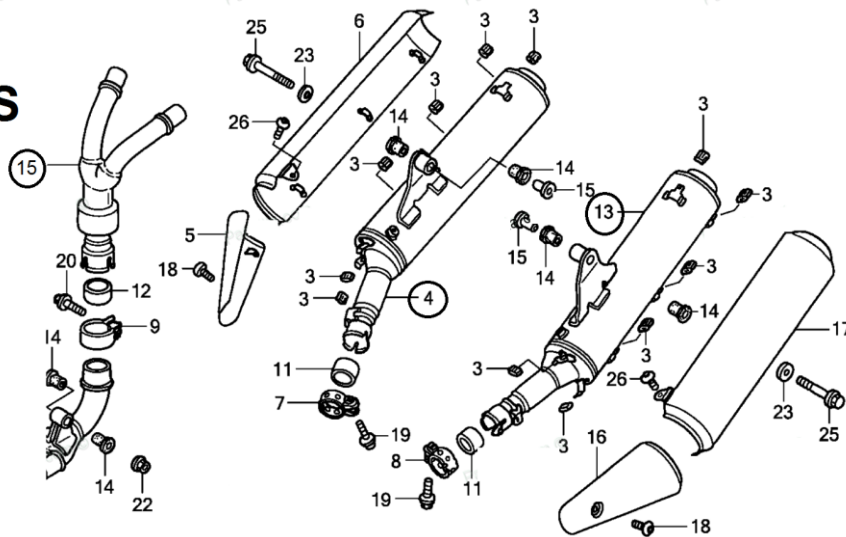

- Clean the collector pipe of old gasket material, dirt and carbon deposits.
- Fit the clamp and insert the link pipe with carbon gasket on to the collector.
- Fit the silencers with clamps on to the link pipe and fit the straps around the silencers and to the brackets/spacers.

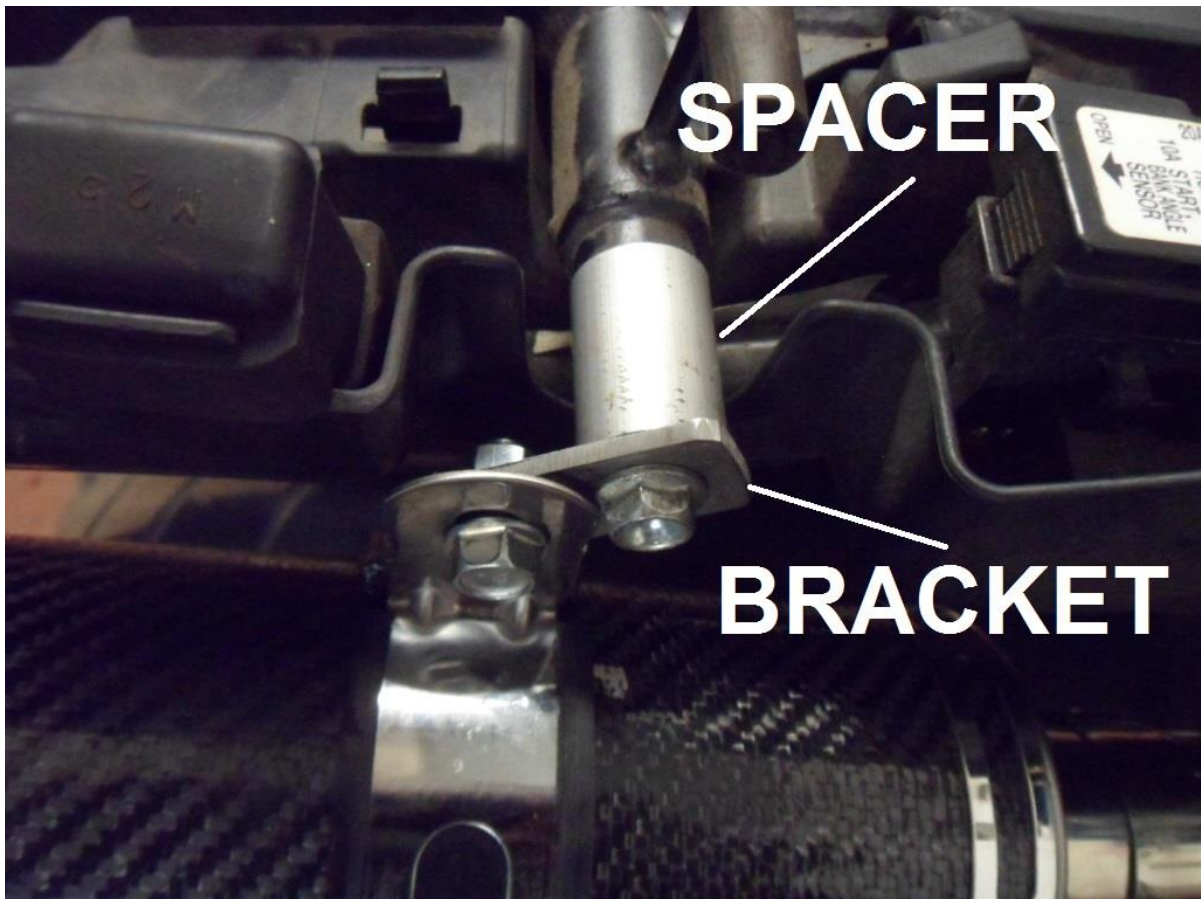

- Starting from the front, working rearwards tighten all clamps and fasteners.
- Re-fit shock absorber and seat cowl. Refer to workshop manual for torque settings or Google/youtube.
- Start the engine and check for leaks.
- After your first ride out, check all fasteners for tightness, especially the baffle bolts.